

BRYSTON

**875HT
OWNER'S
MANUAL**

Table of Contents

Important Safety Instructions

General Introduction

Introduction
Description
Shipping Box & Packing Materials
Installation
Wiring the 875HT

Page 1

Front Panel

Power Switch
LED Indicators

Page 2

Fuses

875HT Rear Panel Input/Output Connections

Single Ended Input Connector
Balanced Input Connector
Balanced versus UnBalanced Inputs
Input Select Switch
Stereo/MonoSwitch
Output Binding Posts

Page 3

875HT Rear Panel Input/Output Connections contd.

Ratings Label
Power Inlet
Power-Up Connector

Page 4

Block Diagram

Typical 5.1 Home Theatre Setup

Page 5

Typical 7.1 Home Theatre Setup

Page 6

High Power 7.1 Home Theatre Setup

Page 7

AC Power Control

External Control Voltage Power Up
AC Power Input

Page 8

Technical Specifications

Page 9

Important Warranty Information

Back Cover

INTRODUCTION

Thank you for choosing the **875 Eight Channel Power Amplifier**. Bryston welcomes any suggestions you may have, or comments regarding the operation of your amplifier. We consider you, our customer, to be Bryston's most important resource, and your opinion is very much appreciated.

DESCRIPTION

The **875HT** is a modular multi-channel audio power amplifier design of 8 x 75 Watts per channel. It is essentially 4 stereo amplifiers. Each stereo pair selects from balanced or single ended inputs, and each stereo pair may be bridged to form a single higher power amplifier channel. The gain of the balanced input is 23dB and the single ended input is 29dB.

The *power up sequence* of the **875HT** may be controlled from a 12v control voltage. The **875** uses 'soft start' power control circuitry to eliminate high inrush currents when A/C power is applied.

WARRANTY (see back page for details)

SHIPPING BOX & PACKING MATERIAL

Please keep the original shipping box and all packing material. This will ensure the amplifier is protected in future transport. In the unlikely event you have a problem and must return it for service you *must* use the proper packing material. Ship the amplifier only in the original packing material, as the unit is not insurable by carriers otherwise.

INSTALLATION

The most important installation consideration is **ventilation**. The **875 series** amplifiers are a convection-cooled. Unrestricted air-flow across its heat sinks is a must. For this reason do not install anything directly above it. Allow 3.5" (2u) to 5" (3u) inches of space above and to the sides of this amplifier. Do not install directly above other heat generating equipment. Any **875** channels thermally shutting down during operation indicates insufficient cooling, and a remedy must be found for cooling the amplifier. Provide a minimum 6" space to the rear of the **875** for ventilation and dressing cables to and from the amplifier.

Never operate the 875 in a vertical position.

WIRING THE 875HT (also see rear panel description)

Speaker wires should be as short as practical. Use quality wire, and if runs are more than 3 meters use at least 12 gauge wire. The speaker binding posts will accept wire up to 3 gauge in size. Bryston can custom build cables for your application.

- **A/C power:**

Before plugging in the power cord be sure your **875** is specified for the **correct A/C voltage** for your locality. The voltage is listed by the power input connector. Never lift the safety ground to the amplifier or remove the ground pin from the plug.

- **Power line conditioners:**

The **875's** performance will not be improved by the use of power line conditioners. In fact most of the time they restrict the flow of current in the power line to the amplifier thereby reducing performance at high output levels.

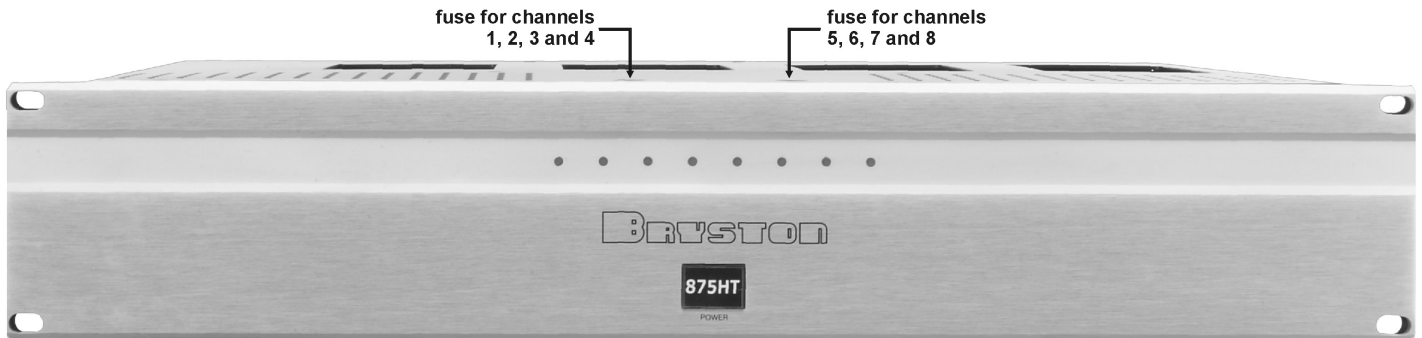

FRONT PANEL OF 875HT-Silver:

FRONT PANEL

POWER switch

The front panel label '875HT POWER' is a switch used to apply or remove A/C line power to the 875 soft start circuitry. Push the switch and the 875 will initiate the start up sequence. The switch cap remains indented when circuits are on. Push the switch again the 875 will initiate the power off sequence.

LED INDICATORS:

Each 875 channel has a single multi-colour LED indicator to monitor the following conditions:

- **Unlit LED: *no power***
The 875 channel led when unlit indicates no A/C mains power is present at the channel. If all channel led indicators are unlit the 875 probably needs only to be powered on. A group of 4 leds not lighting possibly indicates blown group fuse. When checking fuses, unplug the power cord. Use only the specified fuses for your operating voltage. See page 6 for the fuse locations.
- **Red LED: *muted*.**
Each channel normally mutes momentarily during power up and power down sequences.
- **Green LED: *normal operation***
- **Flashing Red LED: *Clipping***
Clipping occurs when the channel output level no longer can follow the level increase at the input (Over driven input condition). When a 875 channel is driven into clipping the channel led will change from green to red then back to green when the level is reduced (Flashing Red). Momentary clipping can be tolerated, however it indicates that maximum un-distorted power has been surpassed and potential speaker damage may result if over load conditions persist. Any amplifier that is constantly operated into clipping indicates a more powerful amplifier is needed for that application.
- **Orange LED: *Thermal Shutdown***
The 875 channel has thermal shutdown circuitry to prevent damage due to over heating. Should thermal shutdown occur, the both stereo channels will mute, and the channel leds will turn orange indicating this condition. When the channels have cooled to a safe operating condition the channels will return to normal operation. Persistent Thermal shutdown indicates steps need to be taken to increase airflow across the channels heat sink. (Also see installation section on ventilation).

FUSES

There are two fuse holders located at the front edge of the top panel. When checking fuses, power down the unit and disconnect the power cord. Use only the specified fuses as indicated on the label located between the two fuse holders on the top panel. See photo at top of page.

875HT REAR PANEL INPUT/OUTPUT CONNECTIONS

1 Single Ended Input Connectors

This input connector for single-ended or *un-balanced* signals accepts standard 'RCA' or 'Phono' connectors.

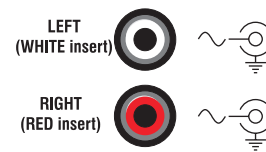

2 Balanced Input connector.

This input connector accepts standard 3 pin 'XLR' male connectors.

Pin 1 is signal ground

Pin 2 is positive phase (+) signal

Pin 3 is negative phase (-) signal

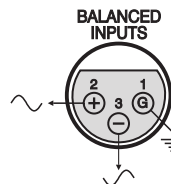

BALANCED vs SINGLE ENDED INPUTS

The balanced input requires a balanced pre-amp source. Balanced systems provide noise protection from external electrical interference, so cable length can be very long (50m or longer). The single ended or unbalanced input is provided for pre-amps without balanced output. Single-ended cables should be kept to 20' (7m) or less. In general never use longer cables than necessary, never coil excess cable length, and run signal wires away from AC power or speaker cables. Whether using balanced or un-balanced cables, use quality, 100% shielded cables with *gold plated* connectors.

- | | |
|---|--|
| <p>Input Sensitivity:</p> <ul style="list-style-type: none"> <input type="checkbox"/> Single-ended inputs: <input type="checkbox"/> Balanced inputs: | <p>850mV input for an output of 75W into 8 ohms</p> <p>1.7V input for an output of 75W into 8 ohms</p> |
|---|--|

3 Input Select Switch.

Each 875-HT channel gives the user the option of switching between either balanced input or single ended input.



4 Input Level Control

Normal or maximum is fully clockwise. Minimum is fully counter clockwise which fully attenuates the input signal.

5 STEREO/MONO SWITCH

The 875HT is configured as 4 stereo amplifiers. Each stereo pair has a Mono/Stereo switch. Stereo configures the channels as independent amplifiers with their own dedicated inputs. Mono configures the stereo pair as a single mono amplifier. The input comes only from the Mono labeled input and the speaker output connections are between the two hot (red) binding posts.

6 OUTPUT BINDING POSTS

In STEREO mode: the RED binding post is connected to the *amplifier output*. Connect to this post the (+) terminal on the loudspeaker. The BLACK binding post is connected to *signal ground*. Connect to this post the (-) terminal on the loud speaker.

In MONO mode: both the RED binding posts are connected to amplifier outputs. The Odd Numbered channels (1, 3, 5 or 7) are the positive (+) phase output and the even numbered channels are the negative (-) phase output

The Output binding posts provide three different interconnect options. Combinations may be used when bi-wiring. See figure below. Cables should be kept as short as practical and should never be terminated with connectors that may become confused for AC power connectors. Cables should be dressed away from input and power cables.

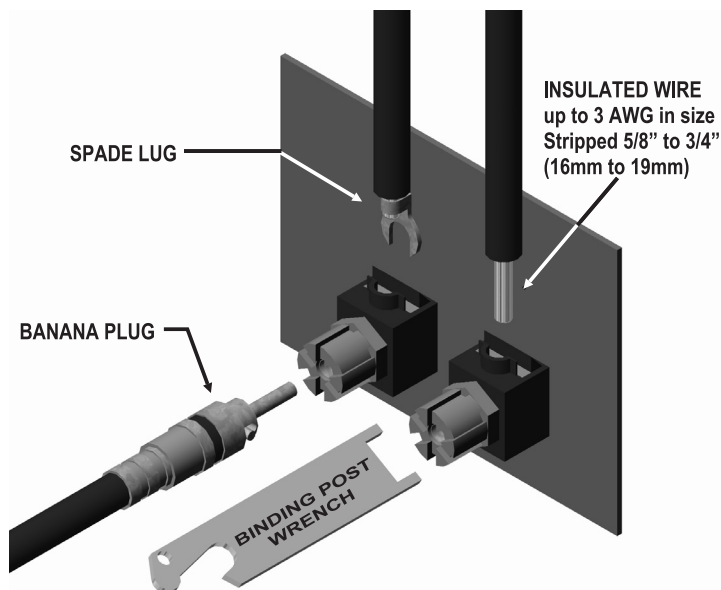

- **BANANA PLUGS** offer a quick disconnect option. Before inserting a banana plug into the binding post be sure to tighten the post nut to avoid rattling and to provide full insertion of the banana plug. Gold plated locking banana plugs are available from Bryston.
- **SPADE LUGS** provide high contact area and secure fastening. Lugs should be gold plated. See diagram for details. Post diameter is 5/16" (8mm),lug width 5/8" (16 mm). Gold plated spade lugs are available from Bryston.
- **STRIPPED BARE** wire up to 3 gauge can be inserted through the hole in the binding post and held in place by tightening the post knob. Additional tightening pressure can be achieved using the wrench provided in the slots of the knob. Do not over tighten or the binding post may become damaged. Note that copper wire is malleable and may require further tightening after the initial installation.

7 RATINGS LABEL

Contains the exact model name, the electrical ratings for that particular model, as well as the serial number and date of manufacture date code (yyww)

8 POWER INLET:

Primary or mains power cord input connector (IEC 320 inlet). Connect the supplied power cord to this connector only after checking the unit label and verifying that the amplifier is set for your local power requirements for A/C voltage and line frequency.

9 POWER-UP CONNECTOR:

When an external 12v control signal is applied between the 2 'IN' pins on the connector, the amplifier will power up. When the 875 has powered up the incoming 12v is handed to the 'OUT' terminals to turn on other equipment. This circuit draws 2 ma to turn the 875 on.

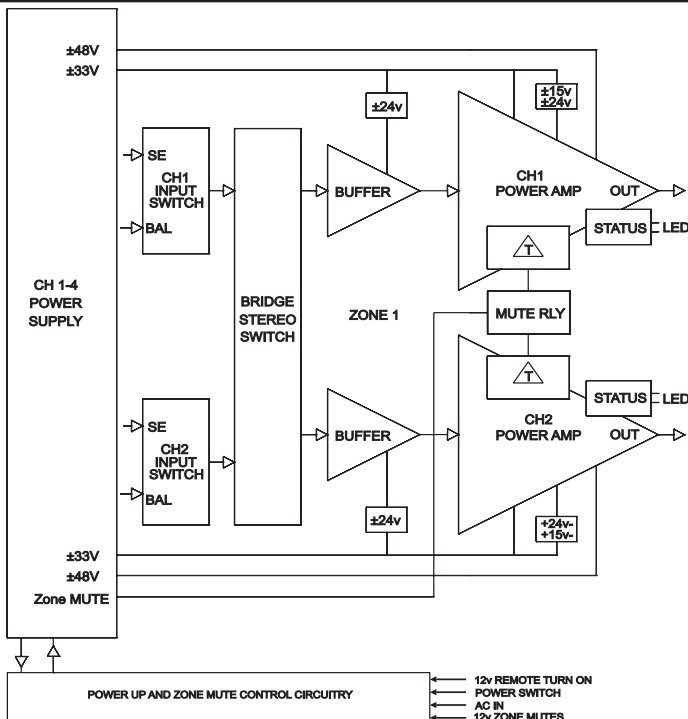
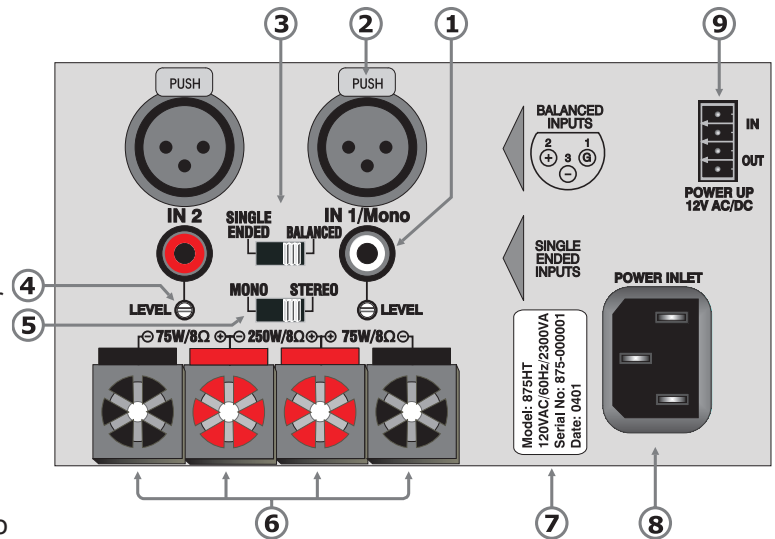

875 SERIES 8-CHANNEL POWER AMPLIFIERS BLOCK DIAGRAM

Only one pair of channels shown. Three more pairs of similarly configured channels are not shown.

Typical 5.1 Home Theatre Setup

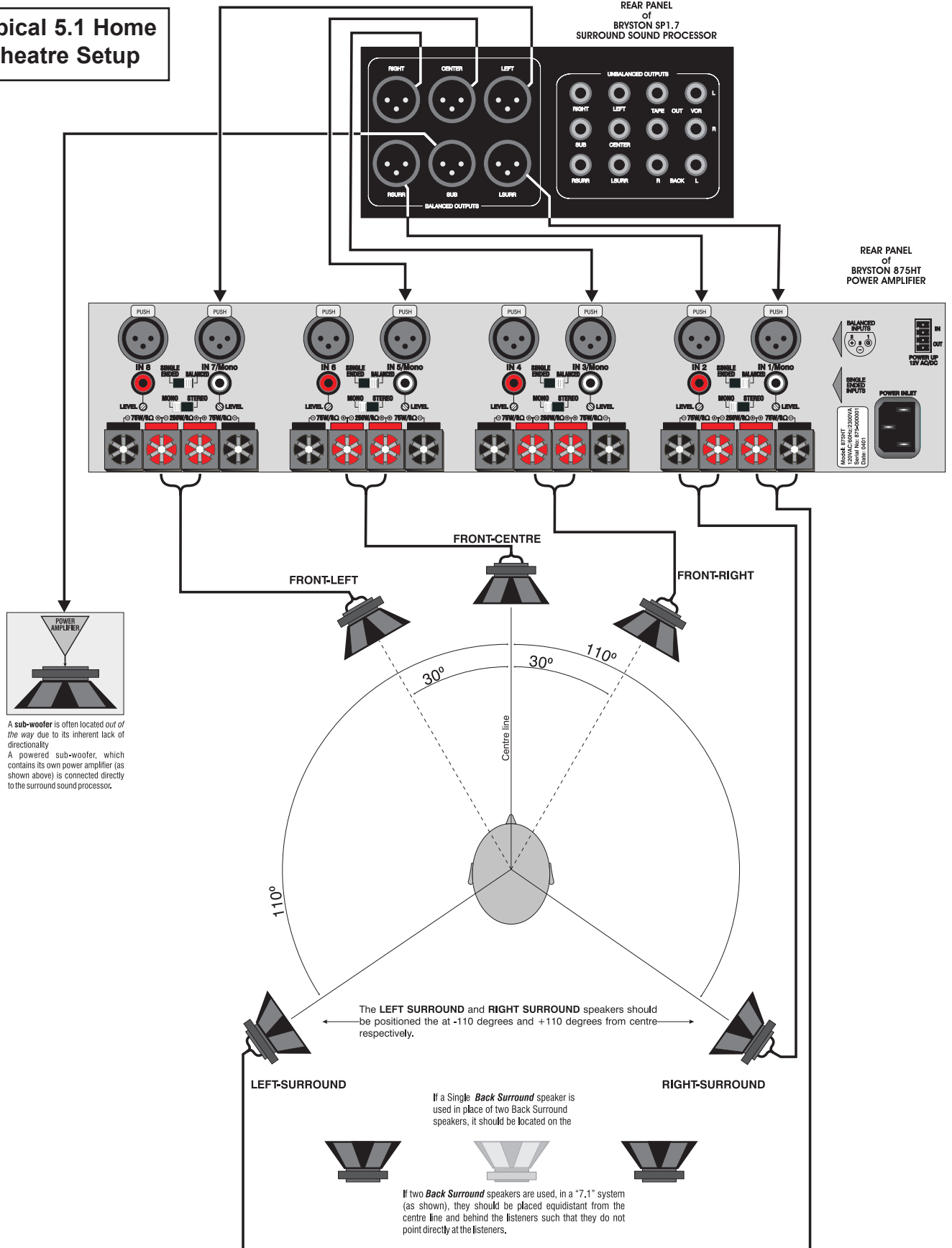

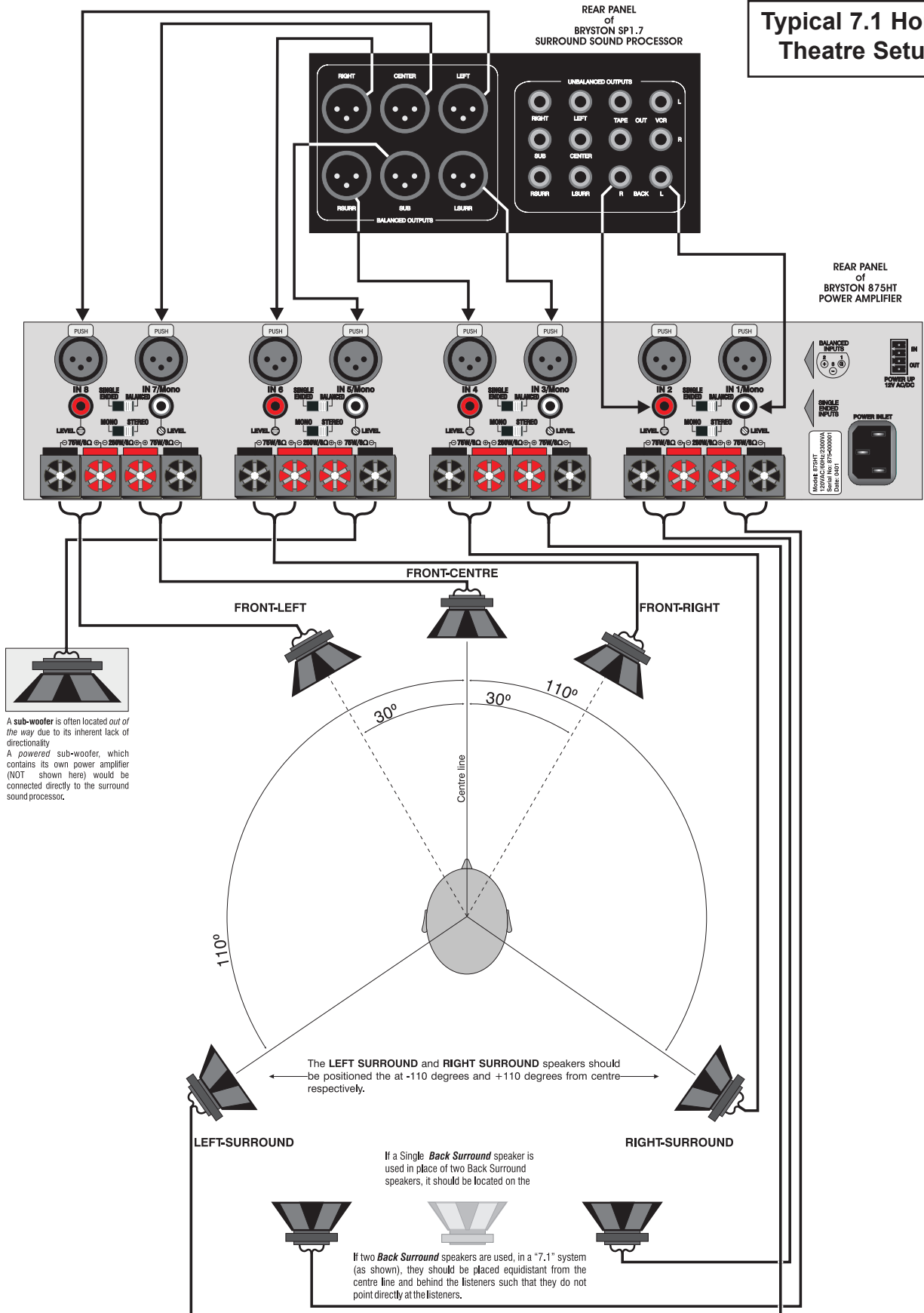

HIGH POWER 7.1 Home Theatre Setup

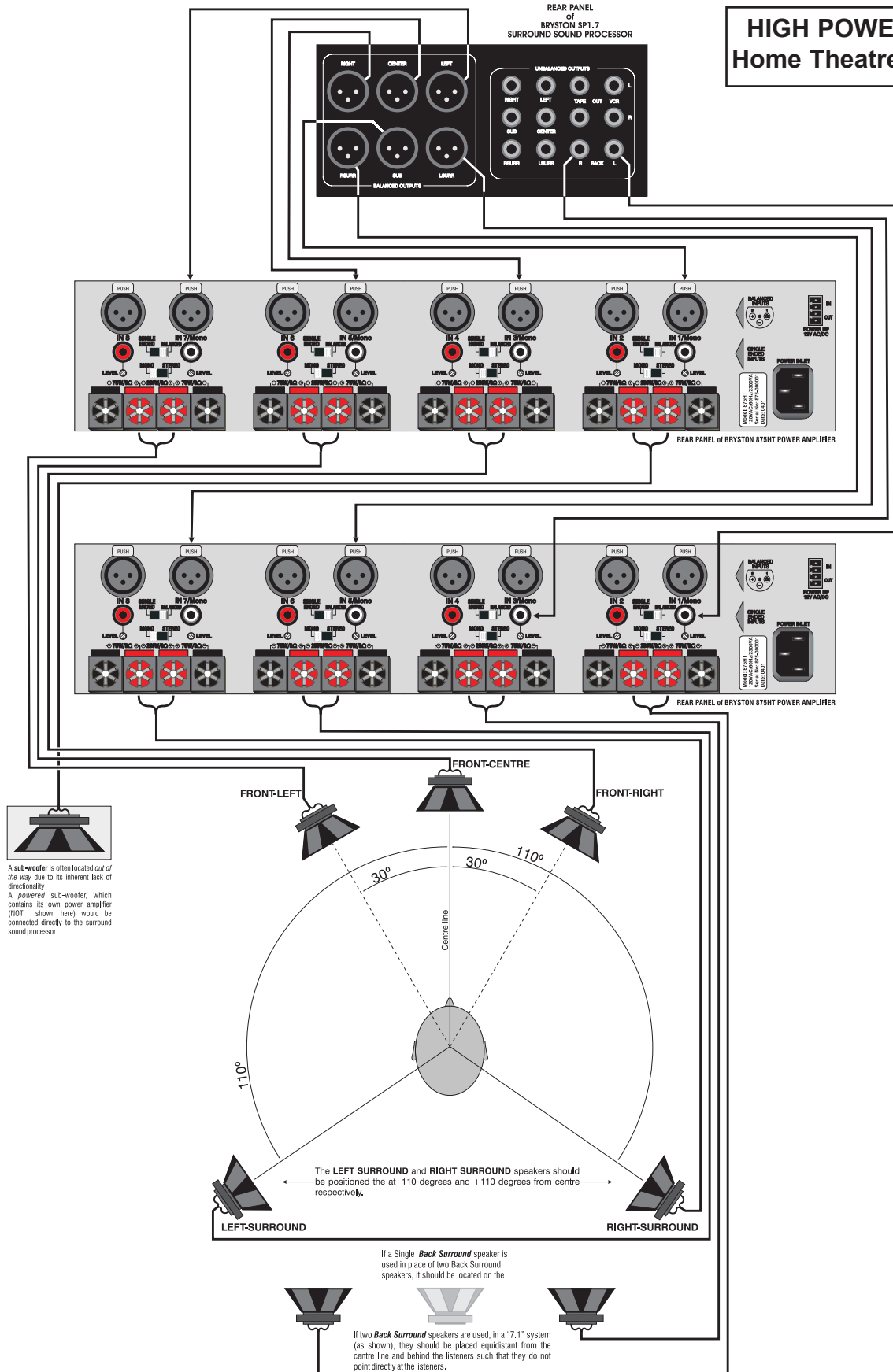

A/C POWER CONTROL

External control voltage power up (Local / external switch)

To power-up the 875 using an external control voltage, supply a 4v to 12v A/C or DC control voltage to the 'IN' terminals of the "Power-Up" connector. The front panel 'Power' switch needs to be off for proper remote operation.

Use paired wire of 22 gauge to 18 gauge between the source device and the 875. The amplifier will now power-up when the control voltage is present (on).

Immediately following power up, the control voltage will appear at the 'OUT' terminals of connector for the control of other equipment.

Removal of the control voltage causes the 875 to turn 'off' and the control voltage at the 'OUT' terminals is interrupted.

AC power input

This is a high current plug for the power cord receptacle. Check that the voltage rating at the right of the connector conforms with your locality. With the front panel power switch in the off position, insert the power cord into the 875, then plug the other end to an appropriate A/C power outlet.

REAR PANEL DETAIL of 875HT AMPLIFIER

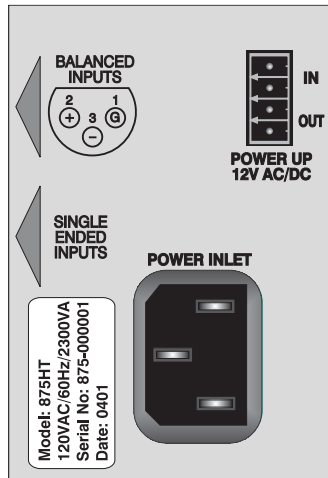

REAR PANEL DETAIL of BRYSTON SP1 SURROUND PROCESSOR/PREAMP

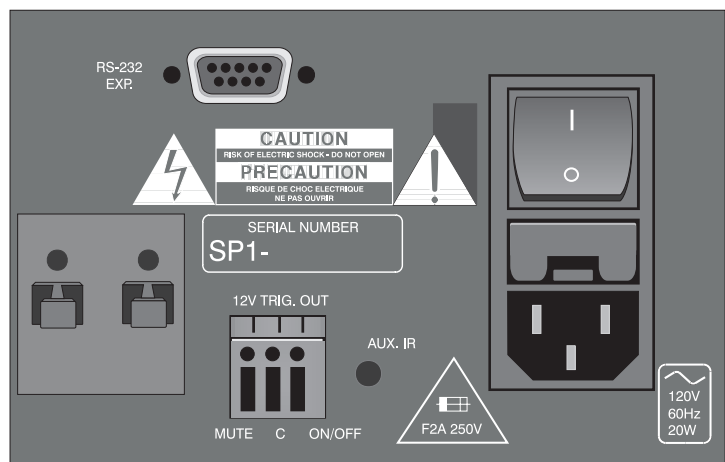

This signal can be used to turn on subsequent voltage controlled devices

stripped & tinned wires
24 to 12 gage stranded copper
Strip length: .28" (7mm)

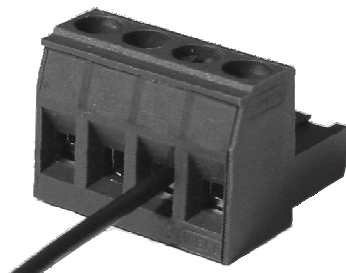

PLUG-IN SCREW TERMINAL CONNECTOR

Insert wires into open elevator style wire clamp and tighten with slot screw driver. Do not over tighten or wires may eventually come lose . Maximum tightening torque is 4.5 lb-in (0.5Nm)

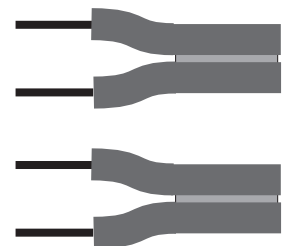

Note:

The 'OUT' terminals of the "Power-Up" connector are connected to the 'IN' terminals once the 875 has powered-up. The control current that appears across the "OUT" terminals is determined by the **source** equipment. The carrying current of the 'OUT' relay is 2 amps. The 875 itself draws less than 3 ma from the control current when operating.

TECHNICAL SPECIFICATIONS

Power Output 75 watts per channel into 8 ohms
100 watts per channel into 4 ohms

Gain Select and Sensitivity 29dB - .850Vin = 75W @ 8 Ohms - single ended input
23dB - 1.7Vin = 75W @ 8 Ohms - balanced input

Input Impedance 20 Kohms single ended
40 Kohms balanced

**Distortion
IMD or THD+noise** < 0.007% 20Hz to 20kHz at 75 watts into 8 ohms,
< 0.010% 20Hz to 20kHz at 100 watts into 4 ohms

Noise Measured with input shorted - 20Hz to 20kHz.
>105dB below rated output 29dB gain (- 68dBu)
>107dB below rated output 23dB gain (- 70dBu)

Slew Rate >60 volts per microsecond

Power Bandwidth <1 Hz to over 100 kHz

Damping Factor Over 500 at 20 Hz, ref. 8 ohms

Dimensions W D H: - 19 (or 17) x 19 x 3.5 inches (2 rack spaces)

Weight: approx.. 25kg - 55 lbs.

Power Consumption &Heat Load

	max power	typical use
single channel 75W @ 8 ohms -	150 Watts	15 Watts
8 channels @ 75W @ 8 ohms -	1200 Watts	120 Watts
Max. Heat Dissipation 8 ohms -	2400 Btu/Hr.	240 Watts
single channel 100W @ 4 ohms -	210 Watts	21 Watts
8 channels @ 100W @ 4 ohms -	1680 Watts	168 Watts
Max. Heat Dissipation 4 ohms -	3500 Btu/Hr.	350 Watts
At Idle -	110 Watts	

IMPORTANT SAFETY INSTRUCTIONS



The lightning flash with arrowhead symbol within an equilateral triangle, is intended to alert the user to the presence of un-insulated “dangerous voltage “ within the product’s enclosure that may be of sufficient magnitude to constitute a risk of electric shock to persons.



The exclamation point within an equilateral triangle is intended to alert the user to the presence of important operating and maintenance (servicing) instructions in the literature accompanying the product.

1. Read these instructions.
2. Keep these instructions.
3. Heed all warnings.
4. Follow all instructions.
5. Do not use this apparatus near water.
6. Clean only with dry cloth.
7. Do not block any ventilation openings. Install in accordance with the manufacturer’s instructions.
8. Do not install near any heat sources such as radiators, heat registers, stoves, or other apparatus (including amplifiers) that produce heat.
9. Do not defeat the safety purpose of the polarized or grounding-type plug. A polarized plug has two blades with one wider than the other. A grounding type plug has two blades and a third grounding prong. The wide blade or the third prong are provided for your safety. If the provided plug does not fit into your outlet, consult an electrician for replacement of the obsolete outlet.
10. Protect the power cord from being walked on or pinched particularly at plugs, convenience receptacles, and the point where they exit from the apparatus.
11. Only use attachments/accessories specified by the manufacturer.
12. Use only with the cart, stand, tripod, bracket, or table specified by the manufacturer, or sold with the apparatus. When a cart is used use caution when moving the cart/apparatus combination to avoid injury from tip-over.
13. Unplug this apparatus during lightning storms or when unused for long periods of time.
14. Refer all servicing to qualified service personnel. Servicing is required when the apparatus has been damaged in any way, such as power-supply cord or plug is damaged, liquid has been spilled or objects have fallen into the apparatus, the apparatus has been exposed to rain or moisture, does not operate normally, or has been dropped.



WARNING: TO REDUCE THE RISK OF FIRE OR ELECTRIC SHOCK, DO NOT EXPOSE THIS APPARATUS TO RAIN OR MOISTURE.

DO NOT EXPOSE THIS EQUIPMENT TO DRIPPING OR SPLASHING AND ENSURE THAT NO OBJECTS FILLED WITH LIQUIDS, SUCH AS VASES, ARE PLACED ON THE EQUIPMENT.

TO COMPLETELY DISCONNECT THIS EQUIPMENT FROM THE AC MAINS, DISCONNECT THE POWER SUPPLY CORD PLUG FROM THE AC RECEPTACLE.

THE MAINS PLUG OF THE POWER SUPPLY CORD SHALL REMAIN READILY OPERABLE.

BRYSTON LIMITED WARRANTY

Bryston analog audio circuits are warranted to be free from manufacturing defects for twenty (20) years from the original date of manufacture. The warranty includes parts and labour.

Bryston Digital circuits and cables are warranted for five years from the original date of manufacture. The warranty includes parts and labour.

Bryston products having motorized moving parts, excluding motorized volume controls, are warranted for three years from the original date of manufacture. The warranty includes parts and labour.

Bryston will remedy the problem by repair or replacement, as we deem necessary, to restore the product to full performance. Bryston will pay shipping costs one way (usually the return portion) during the first three years of warranty coverage.

In the event of a defect or malfunction, contact Bryston’s repair centers for return authorization. Products must be returned using original packaging material only. Packing material may be purchased from Bryston if necessary. This warranty is considered void if the defect, malfunction or failure of the product or any component part was caused by damage (not resulting from a defect or malfunction) or abuse while in the possession of the customer. Tampering by persons other than factory authorized service personnel or failure to fully comply with Bryston operating instructions voids the warranty. This warranty gives you specific legal rights and you may also have other rights which may vary from province to province and country to country.

As of 2006-02-22 Bryston will only warranty Bryston products purchased through authorized Bryston dealers. Bryston products with a date code of 0608 or higher (date code format is “yyww”, where “yy” is the two least significant digits of the year and “ww” is the week of the year) must be accompanied by a copy of the bill-of-sale from a Bryston authorized dealer to qualify for warranty service. The warranty is transferable from the original owner to a subsequent owner as long as a copy of the bill-of-sale from the original authorized Bryston dealer accompanies the re-sale. The copy of the bill of sale to any subsequent owner need ONLY include the Name of the Bryston Authorized Dealer and the Model and Serial number of the Bryston product. The warranty will only be honored in the country of the original purchase unless otherwise pre-authorized by Bryston.

BRYSTON SERVICE in CANADA:

Postal address: **PO. BOX 2170, Stn. Main
PETERBOROUGH, ONTARIO
CANADA K9J 7Y4**

Courier address: **677 NEAL DRIVE
PETERBOROUGH, ONTARIO
CANADA K9J 6X7**

PHONE: 705-742-5325
FAX: 705-742-0882
E-mail: cdnser@bryston.ca

BRYSTON SERVICE in the USA:

**79 COVENTRY ST., Suite 5
NEWPORT, VERMONT
U.S.A. 05855-2100**

PHONE: 802-334-1201
FAX: 802-334-6658
E-mail: usaser@bryston.ca

BRYSTON SERVICE outside Canada and the USA:

contact your local distributor *or*

CHECK OUR WEB SITE: www.bryston.ca
E-MAIL BRYSTON DIRECTLY: cdnser@bryston.ca
FAX BRYSTON DIRECTLY: 01-705-742-0882
PHONE BRYSTON DIRECTLY: 01-705-742-5325