

25mm High Fidelity dome tweeter with a small glass fibre reinforced plastic chassis. The chassis is made square to allow a close mounting to the mid or bass/mid unit, and to fit into a small automobile housing available from SEAS. The neodymium magnet allows a high quality speaker in a very compact design. This unit gives new possibilities in loudspeaker cabinet design, and is well suited for use in automobile sound. The construction of the magnet system gives very low magnetic stray fields since the magnet is enclosed in a soft steel housing. Thus, this unit is immediately ready for Audio-video systems.

The diaphragm is vacuum formed from a precoated fabric. This unique SEAS technology gives a vast improvement in consistency compared with other coating methods. Careful matching of fabric and coating results in a very smooth frequency response throughout the audible frequency range and gives a very high degree of stability against changes in air temperature and humidity. The voice coil is immersed in magnetic fluid, allowing high power handling capacity and simplified crossover design. A hexa grid protects the diaphragm.

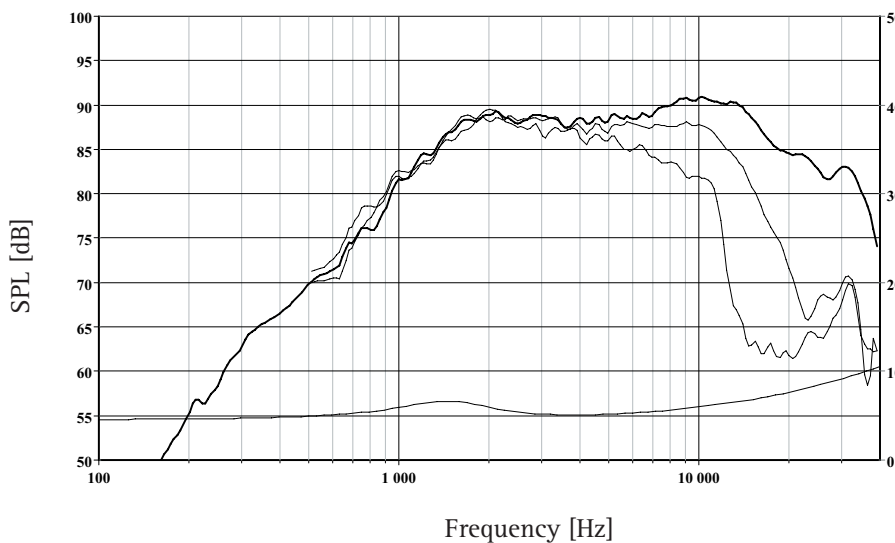

The frequency responses above show measured free field sound pressure in 0, 30, and 60 degrees, mounted in a 0.6m by 0.8m baffle. Input 2.83 Vrms, microphone distance 0.5m, normalized to SPL 1m. The impedance is measured without baffle using a 2V sine signal.

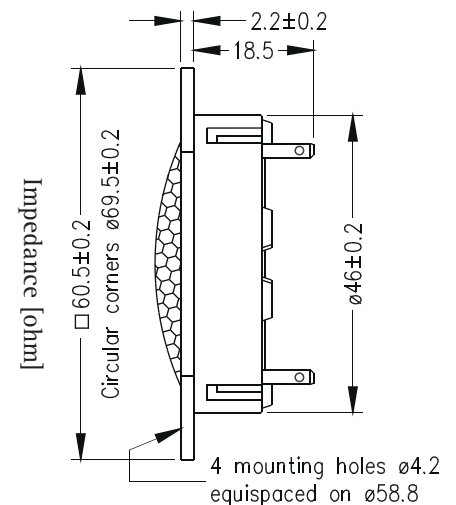

Nominal Impedance	6 Ohms	Voice Coil Resistance	4.8 Ohms
Recommended Frequency Range	3000 - 25000 Hz	Voice Coil Inductance	0.05 mH
Short Term Power Handling *	220 W	Force Factor	2.45 N/A
Long Term Power Handling *	90 W	Free Air Resonance	1800 Hz
Characteristic Sensitivity (2.83V, 1m)	89 dB	Moving Mass	0.3 g
Voice Coil Diameter	26 mm	Effective Piston Area	7.0 cm ²
Voice Coil Height	1.5 mm	Magnetic Gap Flux Density	1.3 T
Air Gap Height	2.0 mm	Magnet Weight	0.01 kg
Linear Coil Travel (p-p)	0.5 mm	Total Weight	0.1 kg