

27mm High Definition soft dome tweeter with diaphragm and integral surround made from SONOLEX, a precoated lightweight fabric material developed by SEAS. Combined with SEAS' unique diaphragm production technology, this material gives superior high frequency response and consistency compared with traditional methods and materials. Furthermore, a very high degree of stability against changes in air temperature and humidity is achieved. The voice coil is wound on an aluminium voice coil former with adequate ventilating holes to eliminate noise from internal air flow.

The voice coil is immersed in low viscosity magnetic fluid, for high power handling capacity and simplified crossover design. A stiff and stable rear chamber with optimal acoustic damping allows 27TFFC to be used with moderately low crossover frequencies. The chassis is precision moulded from glass fibre reinforced plastic, and its front design offers optimum radiation conditions.

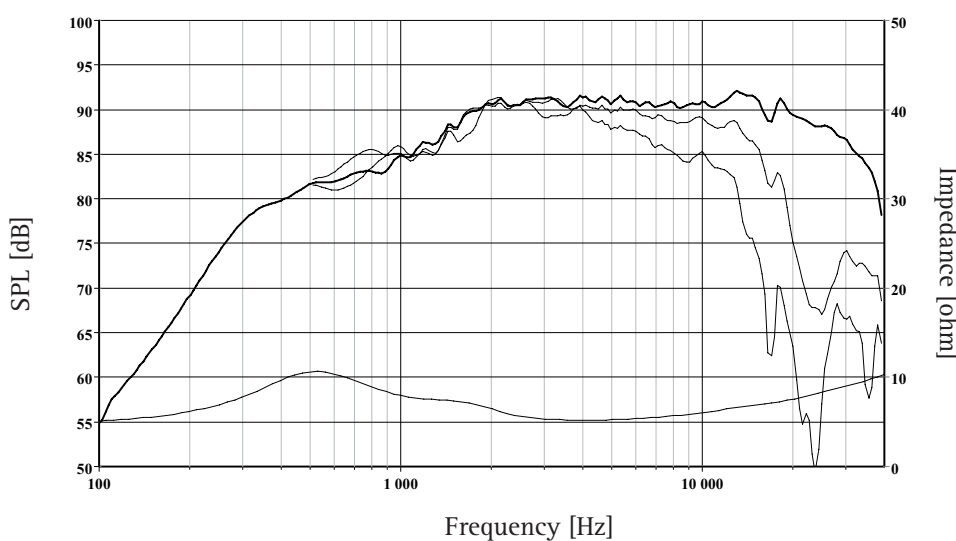

The frequency responses above show measured free field sound pressure in 0, 30, and 60 degrees, mounted in a 0.6m by 0.8m baffle. Input 2.83 Vrms, microphone distance 0.5m, normalized to SPL 1m. The impedance is measured without baffle using a 2V sine signal.

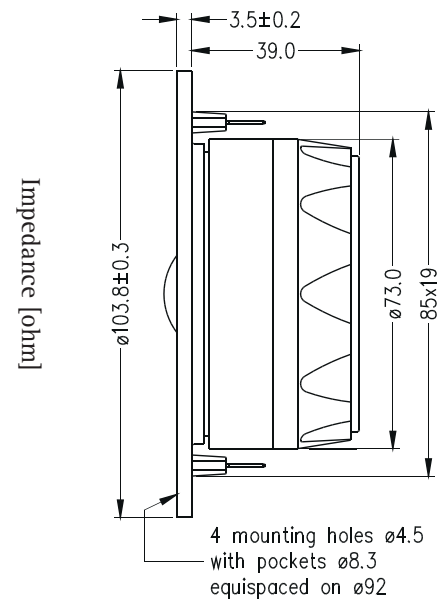

Nominal Impedance	6 Ohms	Voice Coil Resistance	4.8 Ohms
Recommended Frequency Range	2000 - 30000 Hz	Voice Coil Inductance	0.05 mH
Short Term Power Handling *	200 W	Force Factor	3.5 N/A
Long Term Power Handling *	80 W	Free Air Resonance	550 Hz
Characteristic Sensitivity (2.83V, 1m)	91 dB	Moving Mass	0.25 g
Voice Coil Diameter	26 mm	Effective Piston Area	7.6 cm ²
Voice Coil Height	1.5 mm	Magnetic Gap Flux Density	1.8 T
Air Gap Height	2.0 mm	Magnet Weight	0.25 kg
Linear Coil Travel (p-p)	0.5 mm	Total Weight	0.52 kg