



Features

The dynamical cone geometry built with Magnesium composite materials creates an authentic sound. The airflow optimized motor design plus the phase plug construction supports an spacial and agile sound impression.

Die dynamische Membran-Geometrie in Magnesium-Composite-Ausführung fasziniert durch eine authentische Wiedergabe. Der strömungsoptimierte Antrieb und die offene Phase-Plug-Bauweise unterstützen zudem ein räumlich-lebendiges Klangbild.

#1.1669.01

Main technical data

Nominal impedance	Z_n	8	Ω
DC resistance	R_e	6.2	Ω
Resonance frequency 1W	f_r	32	Hz
Resonance frequency TSP	f_r	35	Hz
Suspension compliance	C_{MS}	1.23	mm/N
Mechanical Q	Q_{ms}	6.08	
Electrical Q	Q_{es}	0.34	
Total Q	Q_{ts}	0.32	
Mechanical resistance	R_{MS}	0.66	kg/s

Total moving mass (incl. air mass)	M_{MD}	16.6	g
Effective piston area	S_D	137	cm ²
Voice coil inductance	L_e	0.34	mH
Force factor	$B_L \times l$	7.9	Tm
Xmax electrical	+/-	5.5	mm
Xmax mechanical	+/-	9.5	mm
Equivalent air vol. of suspension	V_{AS}	32.5	dm ³
Characteristic SPL 1 Watt/1m		89	dB SPL
Rated power		80	W

Frequency response

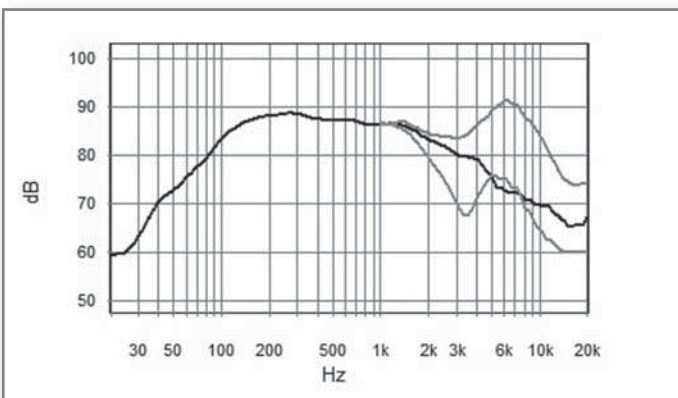

SPL 2,83 V/1m; black 30°, grey 0,60°
Half space; endless baffle; enclosure 700 l

Impedance

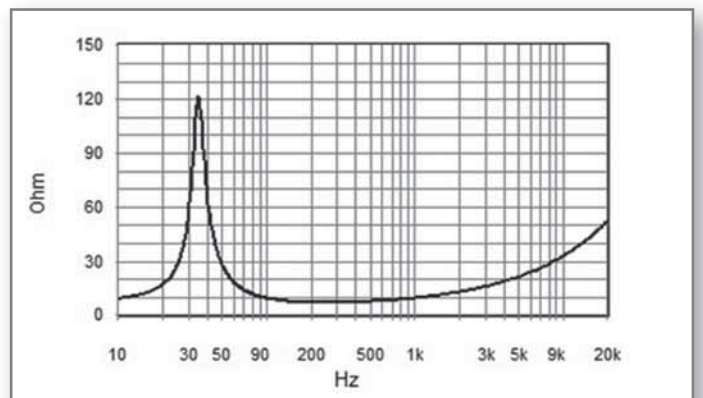

Measured free air without baffle

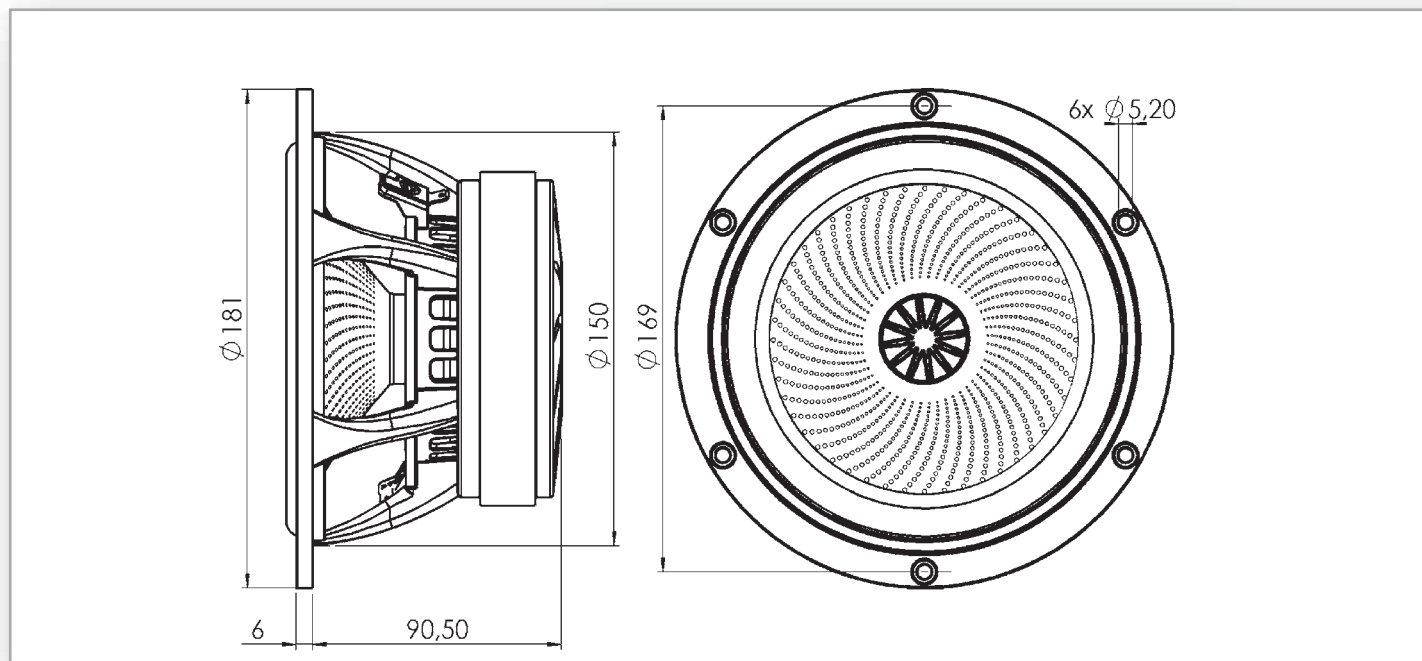

Mechanical data

Overall diameter	181	mm
Cutout diameter	150	mm
Frame depth	6	mm
Overall depth	96.6	mm
Screw holes diameter	5/ 9	mm
Terminal	4.8/ 6.3	mm
Weight	2.66	kg

Voice coil

Diameter	32	mm
Height	17	mm
Wire material	Cu	
Former material	Glass fibre	
Layers	1	

Magnet

Flux density	1.26	T
Height of gap	6	mm
Material	Ferrite	
Dimension	121 x 50	mm
Height	20	mm
Motor type	Overhung	
Ferrofluid	no	

Other data

Recommended frequency range	50-3000	Hz
-----------------------------	---------	----