

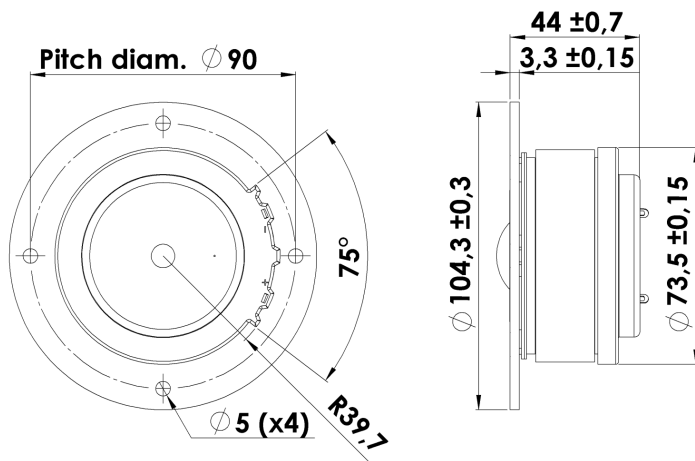

TWEETER

D2904/950000

The Classic tweeters are among the many highly praised designs in Classic series. They have enjoyed success over 3 decades. And still among the best tweeters available. The D2905/9000 tweeter kick-started a new era with a line of very high quality 1" tweeters, today known as -9300, -9500, -9700 and -9800. Despite their many years on the market still used in many top High-End speakers around the world.



KEY FEATURES:

- 1" Textile Dome Diaphragm
- Low Resonant Rear Chamber
- 4 ohm
- Ferro Fluid
- Black Painted Alu Face Plate

T-S Parameters

Resonance frequency [fs]	550 Hz
Mechanical Q factor [Qms]	1.47
Electrical Q factor [Qes]	0.53
Total Q factor [Qts]	0.39
Force factor [Bl]	3.2 Tm
Mechanical resistance [Rms]	1.05 kg/s
Moving mass [Mms]	0.45 g
Compliance [Cms]	0.19 mm/N
Effective diaph. diameter [D]	35 mm
Effective piston area [Sd]	9.5 cm ²
Equivalent volume [Vas]	0.02 l
Sensitivity (2.83V/1m)	91 dB
Ratio Bl/ \sqrt{Re}	1.71 N/ \sqrt{V}
Ratio fs/Qts	1421 Hz

Notes:

IEC specs. refer to IEC 60268-5 third edition.
All Scan-Speak products are RoHS compliant.
Data are subject to change without notice.
Datasheet updated: April 30, 2013.

Electrical Data

Nominal impedance [Zn]	4 Ω
Minimum impedance [Zmin]	4.3 Ω
Maximum impedance [Zo]	13.3 Ω
DC resistance [Re]	3.5 Ω
Voice coil inductance [Le]	0.05 mH

Power Handling

100h RMS noise test (IEC 17.1)*	150 W
Long-term max power (IEC 17.3)*	430 W

*Filter: 2. order HP Butterworth, 2.5 kHz

Voice Coil & Magnet Data

Voice coil diameter	28 mm
Voice coil height	2.5 mm
Voice coil layers	2
Height of gap	2.5 mm
Linear excursion	± 0.1 mm
Max mech. excursion	± 1.5 mm
Unit weight	0.7 kg



TWEETER

D2904/950000

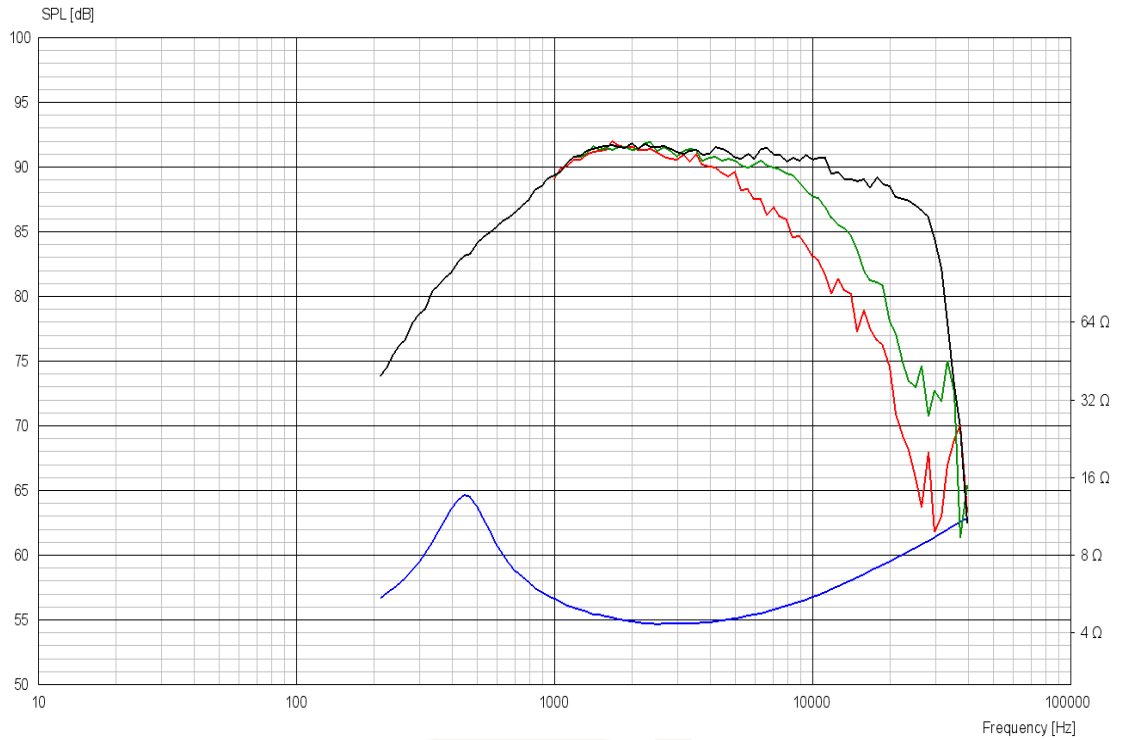

Advanced Parameters (Preliminary)

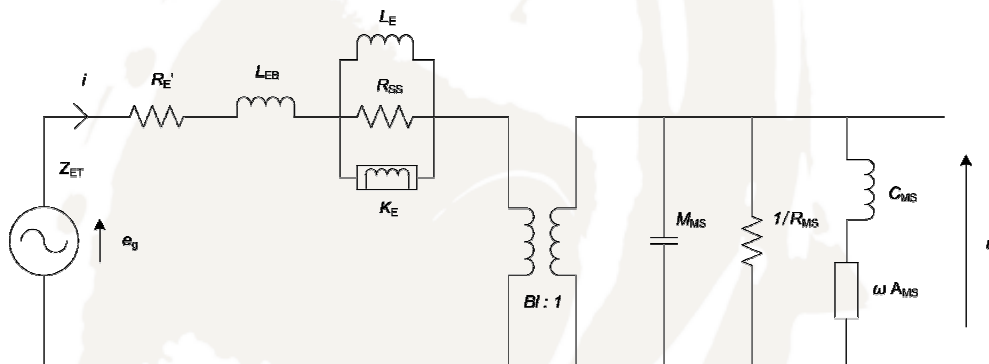

Electrical data

Resistance [$R_{e'}$]	- Ω
Free inductance [L_{eB}]	- mH
Bound inductance [L_e]	- mH
Semi-inductance [K_e]	- SH
Shunt resistance [R_{ss}]	- Ω

Mechanical Data

Force Factor [BI]	- Tm
Moving mass [M_{ms}]	- g
Compliance [C_{ms}]	- mm/N
Mechanical resistance [R_{ms}]	- kg/s
Admittance [A_{ms}]	- mm/N