

The Dynaudio Esotec mobile loudspeakers follow in the longstanding tradition of the company's renowned home audio driver designs.

The new Esotec MD 102 tweeter is a soft-dome design as characteristic of Dynaudio. The fine soft dome features a special coating to facilitate an extended high frequency response free of distortion. The compact, shallow depth MD 102 tweeter features a 28 mm (1.1 inch) diameter surface area that is approximately 60% greater than that of conventional car audio tweeters. The optimized dome geometry provides greatly improved dispersion characteristics, enabling the MD 102 tweeter to offer exceptional performance even when mounted off of the listening axis. The dome coating serves to eliminate any high frequency break-ups, while providing improved damping. To eliminate high frequency distortions caused by reflections from inside the structure, the MD 102 tweeter rear chamber is also sealed and acoustically damped to eliminate high frequency distortion, which could be caused by back-wave reflections, while ferrofluid cooling adds damping and additional power handling.

The extremely smooth and incredibly detailed high frequency reproduction characteristic of the Dynaudio sound is ensured by the all-new Esotec soft-dome tweeter, which features the latest Dynaudio technological innovations. For the most authentic high-frequency reproduction – powerful Neodymium – one of the most efficient but also most expensive magnetic materials for loudspeaker construction is used in the tweeter magnet systems.

The soft-dome tweeter design topology allows unrestricted dynamics and a linear frequency response with extremely low distortion. The MD 102 features an aluminum voice coil, another Dynaudio hallmark, which has been updated and improved via an increased coil height with additional windings to allow an increased range of linear excursion within the magnetic field. Furthermore, as a result of the low moving mass of the new voice coil, a higher maximum output level and increased dynamics are achieved, while the frequency range has been expanded, thus allowing a better integration with the upper midrange frequencies to deliver a more natural sound with an open and detailed, and incredibly transparent reproduction of the high frequencies.

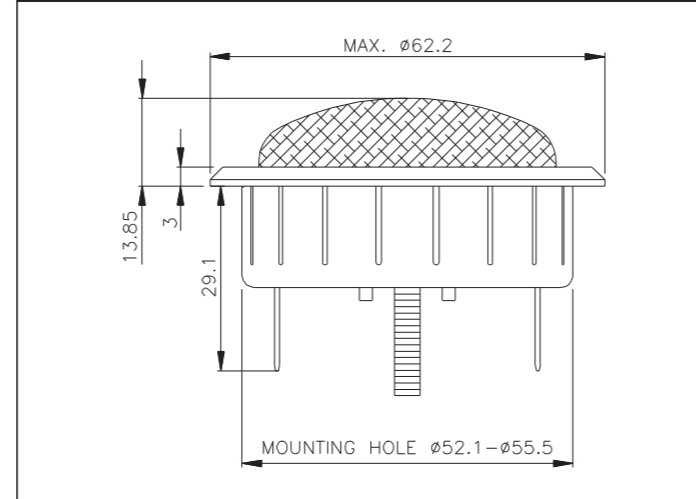

Thiele Small Parameters		
Nominal impedance	Znom	8 Ω
DC resistance	Re	5.6 Ω
Voice coil inductance	Le	- mH
Resonance frequency	fs	1300 Hz
Mechanical Q factor	Qms	-
Electrical Q factor	Qes	-
Total Q factor	Qts	-
Mechanical resistance	Rms	- kg/s
Moving mass (incl. air load)	Mms	- g
Suspension compliance	Cms	- mm/N
Effective dome diameter	d	- mm
Effective piston area	Sd	7.7 cm ²
Equivalent volume	Vas	- l
Force factor	BL	- Tm
Recommended frequency range		2200–30000 Hz

Magnet and Voice Coil Properties		
Voice coil diameter	dc	28 mm
Voice coil height	hc	1.7 mm
Linear excursion, peak to peak		- mm
Max. excursion, peak to peak		- mm

Power Handling		
Nominal long term IEC		100 W
Transient (10 ms)		500 W

Mechanical Properties		
Net weight		0.126 kg
Overall dimension		Ø 62.2 x 43 mm

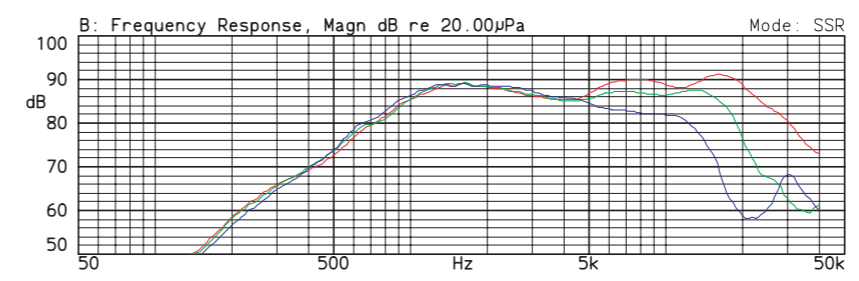
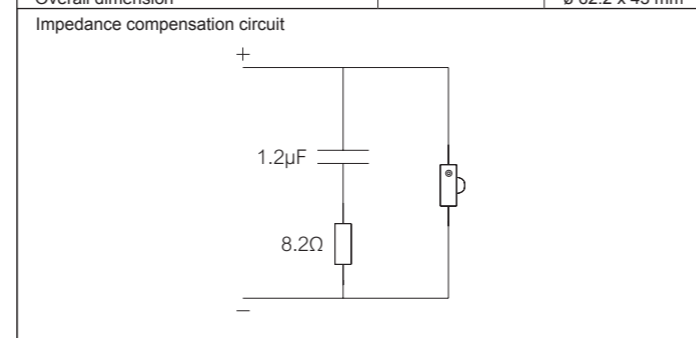

SPL
 Red line: on-axis response
 Green line: 30° horizontal
 Blue line: 60° horizontal
 Measurement conditions:
 Level: 2.83 V
 Distance: 1 m
 Measured in a large baffle

- Facts**
- Coated textile dome eliminates any high frequency break-ups
 - Powerful neodymium magnet system
 - Protective grille
 - Open and detailed high frequency reproduction
 - Damped cavity beneath the dome

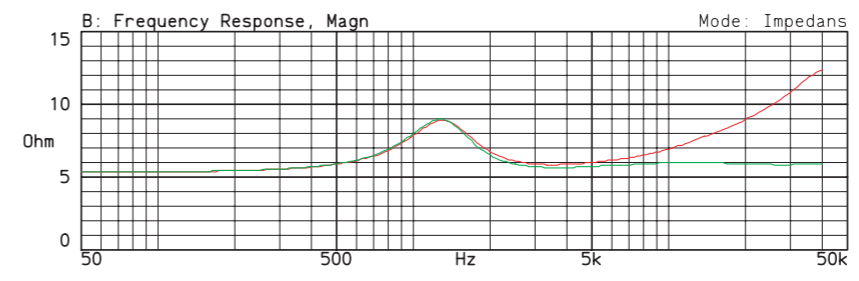

Impedance
 (with and without impedance correction circuit)
 Red line: impedance, free air
 Green line: impedance, free air with compensation.
 Measurement conditions:
 Level: 3.16 V, 50 ohm
 Driver in free air

- Ferrofluid adds damping and increases power handling
- Aluminium voice coil wire results in a low moving mass
- Shallow mounting depth
- Strong 6.4 mm terminals