

The new Esotar<sup>2</sup> 430 midrange features a geometrically optimized 3.5" diameter MSP (magnesium silicate polymer) cone, a material providing the ideal combination of stiffness, low weight and excellent inner damping.

The diaphragm and dust cap are molded as one piece. A new magnet/motor system incorporates powerful neodymium magnets and a large vented pole piece. The relatively large diameter aluminum voice coil wire provides for a low moving mass, and is wound on an aluminum former to maintain the extremely light weight.

Built into a rigid, die-cast solid aluminum frame with aerodynamically shaped ribs, in conjunction with the powerful motor, the characteristic Esotar<sup>2</sup> low-mass driver construction provides excellent transient response, speed and precision, with smooth high frequency roll off and a natural midrange reproduction. The Esotar<sup>2</sup> 430 driver exhibits very low distortion even at extreme volumes, while the transparency and detail of its midrange quality can best be described as holographic.

The Dynaudio Esotar<sup>2</sup> automotive loudspeaker series represent the highest level of automotive music reproduction – not just for Dynaudio but for the entire arena of mobile audio. The compact Dynaudio Esotar<sup>2</sup> 430 expands the possibilities for system installations with a performance that was previously not possible, and is a perfect complement to the performance benchmarks set by the Esotar<sup>2</sup> loudspeaker separates.

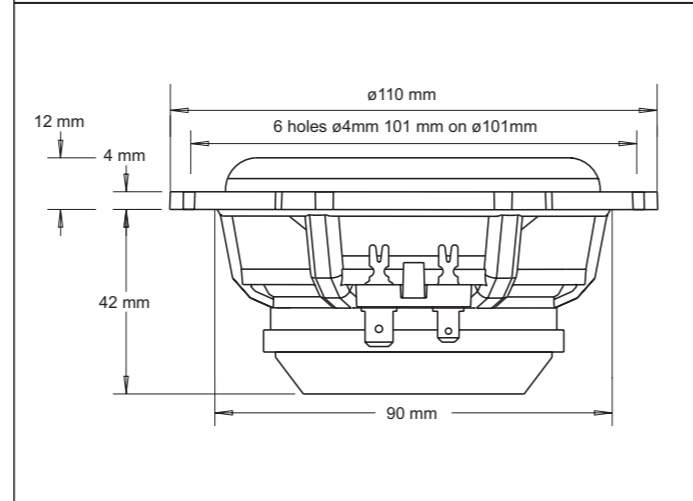

Thiele Small Parameters		
Nominal impedance	Znom	4 Ω
DC resistance	Re	4 Ω
Voice coil inductance	Le	0.19 mH
Resonance frequency	fs	64 Hz
Mechanical Q factor	Qms	1.5
Electrical Q factor	Qes	0.21
Total Q factor	Qts	0.18
Mechanical resistance	Rms	1.3 kg/s
Moving mass (incl. air load)	Mms	4.9 g
Suspension compliance	Cms	1.2 mm/N
Effective dome diameter	d	75 mm
Effective piston area	Sd	45 cm <sup>2</sup>
Equivalent volume	Vas	3.5 l
Force factor	BL	6.2 Tm
Recommended frequency range		200–7000 Hz

Magnet and Voice Coil Properties		
Voice coil diameter	dc	34 mm
Voice coil height	hc	9.5 mm
Linear excursion, peak to peak		4.9 mm
Max. excursion, peak to peak		21 mm

Power Handling		
Nominal long term IEC		150 W
Transient (10 ms)		1000 W

Mechanical Properties		
Net weight		0.47 kg
Overall dimension		ø 110 x 49 mm

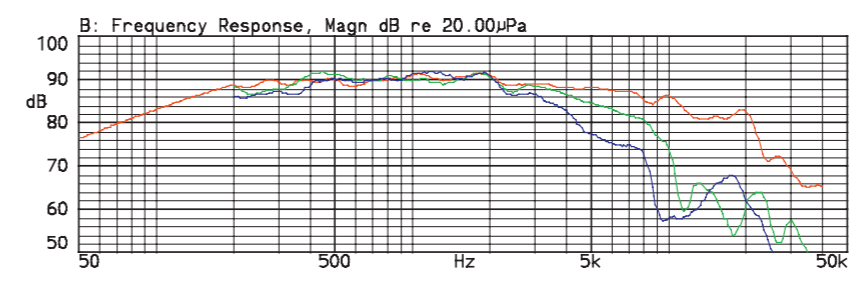
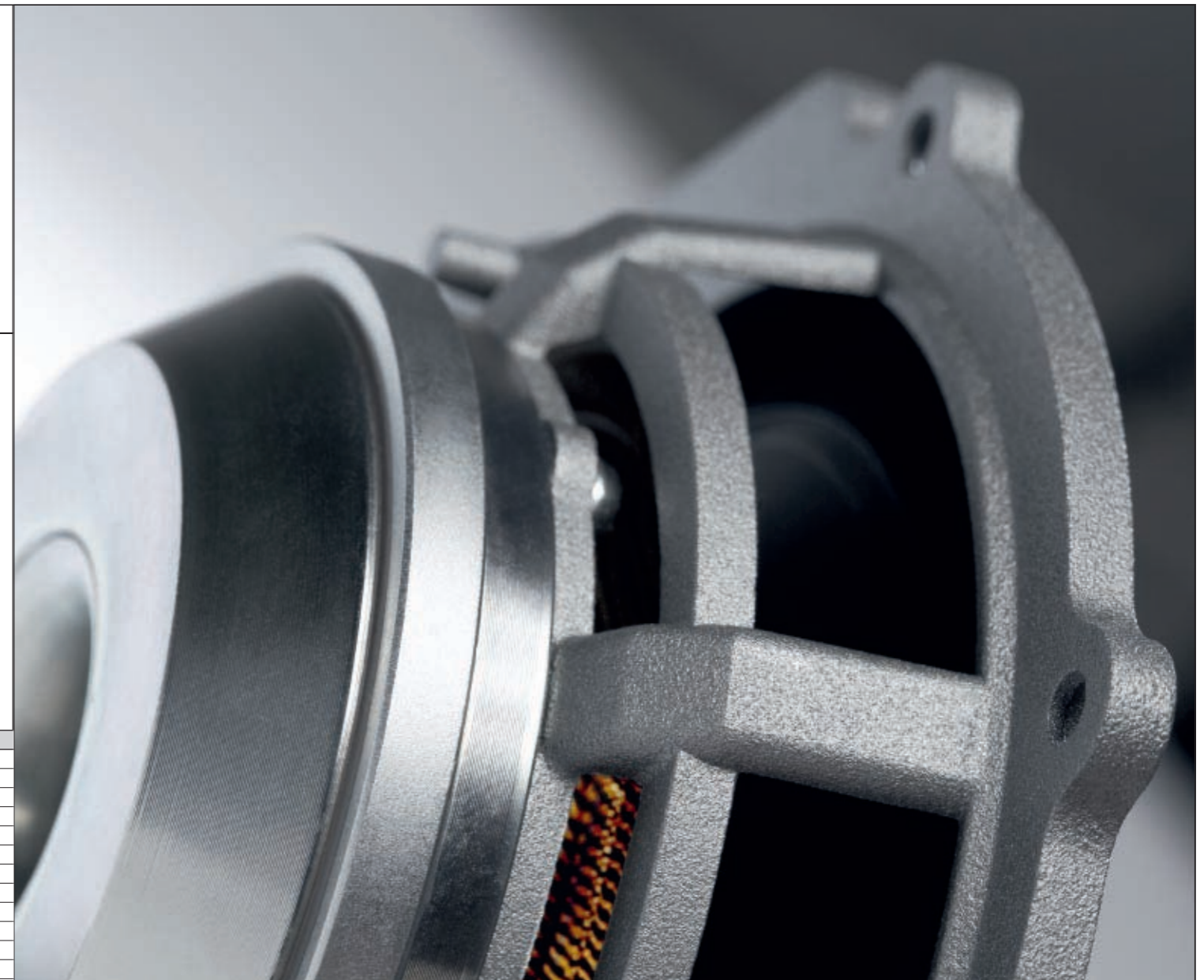
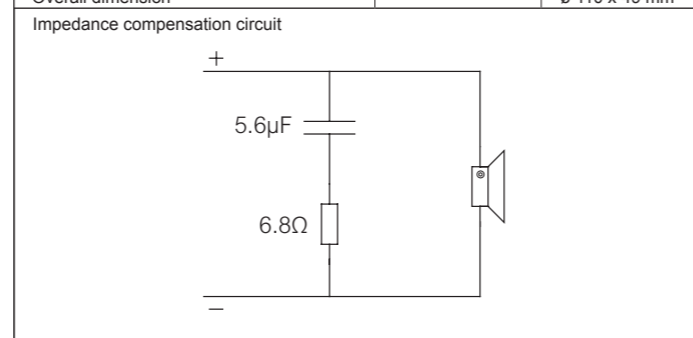

**SPL**  
 Red line: on-axis response  
 Green line: 30° horizontal  
 Blue line: 60° horizontal  
 Measurement conditions:  
 Level: 2.83 V  
 Distance: 1 m  
 Box volume: 4 l

**Facts**  
 Diaphragm and dust cap moulded as one piece  
 Internal double neodymium magnet system with vented pole piece  
 Aluminium voice coil wire provides for a low moving mass, wound on aluminium former

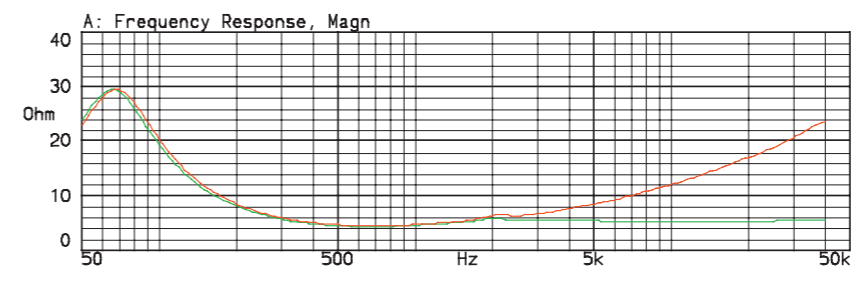

**Impedance**  
 (with and without impedance correction circuit)  
 Red line: impedance, free air  
 Green line: impedance, free air with compensation.  
 Measurement conditions:  
 Level: 3.16 V, 50 ohm  
 Driver in free air

Rigid die-cast chassis with aerodynamically shaped ribs  
 Materials and parameters are optimized for the harsh environmental conditions in a car  
 Smooth high-frequency roll-off  
 Natural midrange reproduction