

The Dynaudio Esotec mid/woofers also utilize the same core technology as the company's home audio and professional studio loudspeaker products, with materials and parameters fully optimized for the particular conditions typical of in-car installations. All Esotec models are available in various sizes, all characterized by an ultra linear frequency response and Dynaudio's exemplary sonic performance.

The most compact of the new Esotec car series mid/woofers, the new MW 152 is a compact 15 cm (5.75 inch) diameter driver with a 75 mm (3 inch) diameter voice coil. As is the case with the full range of Dynaudio woofers, the cone diaphragm is composed of a proprietary MSP (magnesium silicate polymer) material developed by Dynaudio – a low-distortion material characterized by a lack of coloration that proves essential to the unique Dynaudio sound. The MW 152 exhibits a smooth frequency response both on- and off-axis, with incredibly low distortion. The MW 152 delivers excellent midrange reproduction and is the perfect choice for any small, high-performance two- or three-way system.

The woofer motor assemblies of the Esotec mid/woofers are built into torsionally rigid die-cast aluminium baskets (a high-strength stamped steel basket is utilized on the MW 162 GT and MW 182 model variants), which have been optimized to eliminate air turbulence and resonance and the adverse effects of such. The aerodynamically shaped ribs of the Dynaudio die cast driver frames serve to eliminate virtually all reflections and tonal aberrations created by the traditional driver frame, and ensure the highest degree of mechanical performance at an extremely low weight.

The low suspension compliance of the MW 152 makes it perfectly suited for smaller enclosures typical of most in-car installations, while also allowing it to be utilized without a dedicated enclosure in free-air mounting applications.

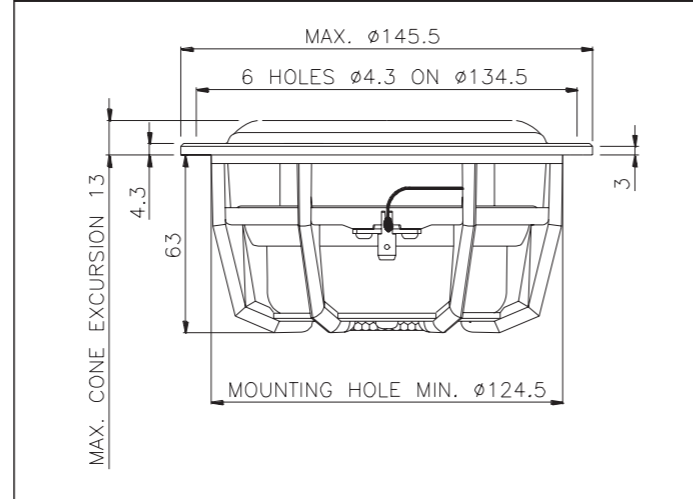

Thiele Small Parameters		
Nominal impedance	Znom	4 Ω
DC resistance	Re	3.0 Ω
Voice coil inductance	Le	0.24 mH
Resonance frequency	fs	70 Hz
Mechanical Q factor	Qms	1.9
Electrical Q factor	Qes	0.63
Total Q factor	Qts	0.47
Mechanical resistance	Rms	3.1 kg/s
Moving mass (incl. air load)	Mms	14 g
Suspension compliance	Cms	0.38 mm/N
Effective dome diameter	d	105 mm
Effective piston area	Sd	87 cm ²
Equivalent volume	Vas	4 l
Force factor	BL	5.4 Tm
Recommended frequency range		55–3500 Hz

Magnet and Voice Coil Properties		
Voice coil diameter	dc	75 mm
Voice coil height	hc	10.9 mm
Linear excursion, peak to peak		6 mm
Max. excursion, peak to peak		15 mm

Power Handling		
Nominal long term IEC		100 W
Transient (10 ms)		1000 W

Mechanical Properties		
Net weight		1.1 kg
Overall dimension		ø 145.5 x 70 mm

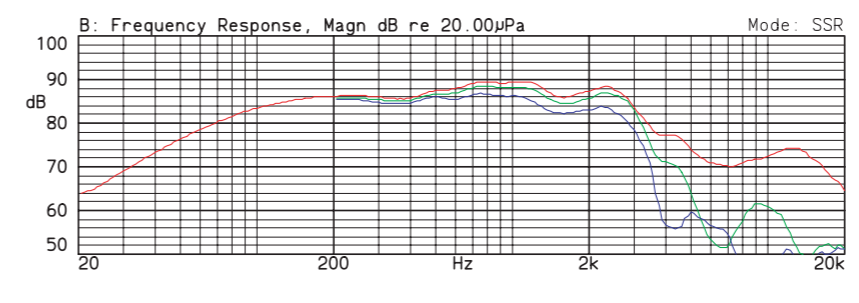
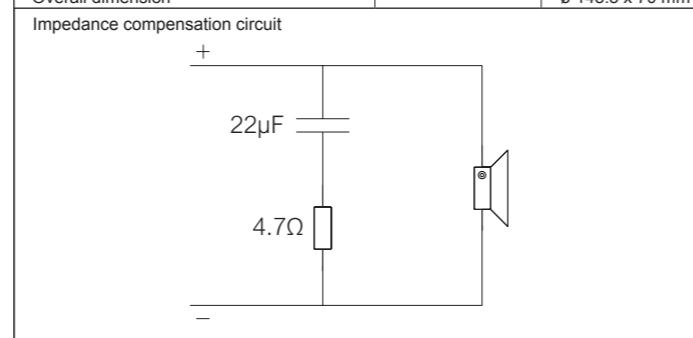

SPL
(Frequency response: on-axis, 30° and 60° off-axis)
Red line: on-axis response
Green line: 30° horizontal
Blue line: 60° horizontal
Measurement conditions:
Level: 2.83 V
Distance: 1 m
Box volume: 8.4 l

Facts
Diaphragm and dust cap moulded as one piece
Large 75 mm voice coil ensures high power handling
Internal double magnet system with vented pole piece
Aluminium voice coil wire provides for a low moving mass

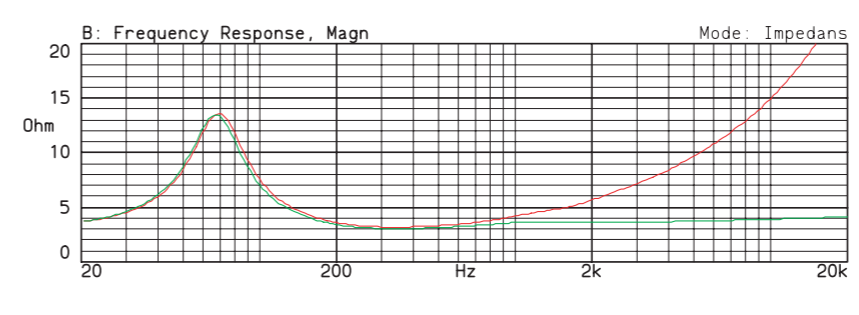

Impedance
(with and without impedance correction circuit)
Red line: impedance, free air
Green line: impedance, free air with compensation.
Measurement conditions:
Level: 2 V, 10 ohm
Driver in free air

Rigid die-cast chassis with aerodynamically shaped ribs
Materials and parameters are optimized for the harsh environmental conditions in a car
Smooth high-frequency roll-off