

The Esotec MW 162 mid/woofer is a medium sized 17 cm (6.5 inch) diameter driver that combines a clear and detailed midrange with a strong and powerful bass response.

Another characteristic typical of Dynaudio drivers and carried through in the new Esotec mobile series woofers is the diffraction-optimized shape of the MSP cone's characteristic curvature, which further improves imaging so that even at short listening distances as typical of most in-car installations a realistic, true three-dimensional sound-stage can be enjoyed. Molding the diaphragm and dust cap into a one-piece flat-membrane results in a controlled roll off and high dynamic range. In relation to the total cone surface area, the 75 mm (3 inch) voice coil is exceptionally large in diameter, allowing a most precise conversion of the amplifier's signal to music. The result is un-compromised, direct music enjoyment.

All of the Esotec MW (mid/woofer) model variants employ Dynaudio's customary oversized aluminium voice coil, which feature an uncharacteristically large diameter coil wound on a strong and temperature stable former to drive the geometrically optimized rigid MSP cone diaphragm. The Esotec mid/woofers have all been further upgraded with a brand-new suspension. The new spider allows greater mechanical movement of the cone, increasing excursion while allowing a higher maximum SPL and improved low bass performance.

The use of Dynaudio's large diameter aluminium voice coils increases thermal handling capabilities tremendously, allowing the drivers to operate within an ideal temperature range, even at high continuous power levels and during powerful music transients. Dynamic impulses are reproduced precisely and without distortion, even at high volume levels, while impressive sound quality and high power handling capability are achieved.

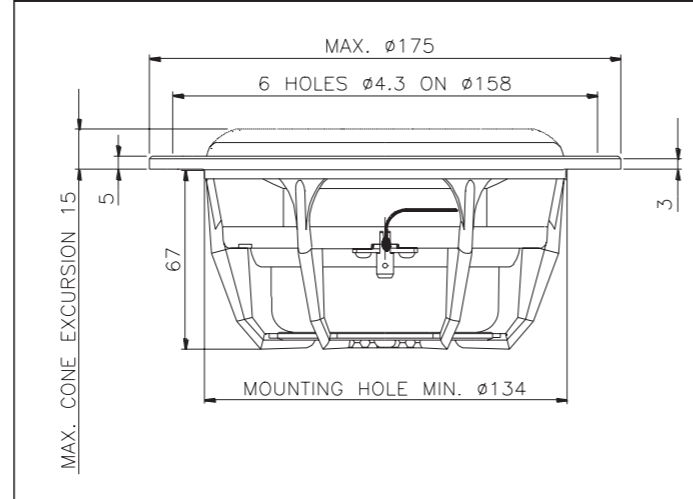

Thiele Small Parameters		
Nominal impedance	Znom	4 Ω
DC resistance	Re	3.1 Ω
Voice coil inductance	Le	0.22 mH
Resonance frequency	fs	55 Hz
Mechanical Q factor	Qms	2.2
Electrical Q factor	Qes	0.57
Total Q factor	Qts	0.45
Mechanical resistance	Rms	2.7 kg/s
Moving mass (incl. air load)	Mms	17.4 g
Suspension compliance	Cms	0.48 mm/N
Effective dome diameter	d	124 mm
Effective piston area	Sd	120 cm²
Equivalent volume	Vas	9.8 l
Force factor	BL	5.7 Tm
Recommended frequency range		40–4000 Hz

Magnet and Voice Coil Properties		
Voice coil diameter	dc	75 mm
Voice coil height	hc	10.9 mm
Linear excursion, peak to peak		6 mm
Max. excursion, peak to peak		17 mm

Power Handling		
Nominal long term IEC		120 W
Transient (10 ms)		1000 W

Mechanical Properties		
Net weight		1.2 kg
Overall dimension		Ø 175 x 77 mm

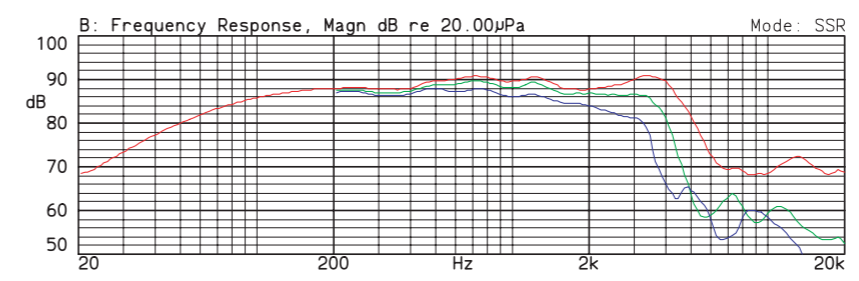
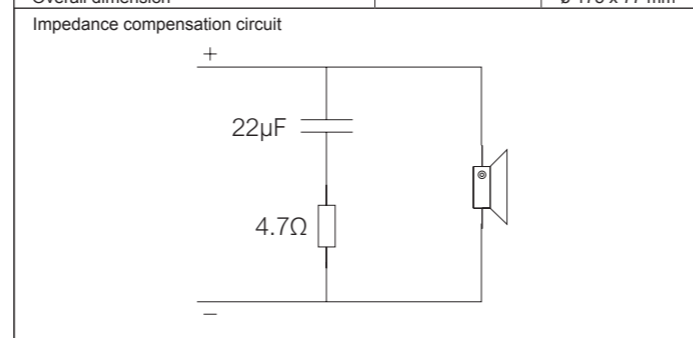

SPL
(Frequency response: on-axis, 30° and 60° off-axis)
Red line: on-axis response
Green line: 30° horizontal
Blue line: 60° horizontal
Measurement conditions:
Level: 2.83 V
Distance: 1 m
Box volume: 15.6 l

Facts
Diaphragm and dust cap moulded as one piece
Large 75 mm voice coil ensures high power handling
Internal double magnet system with vented pole piece
Aluminium voice coil wire provides for a low moving mass

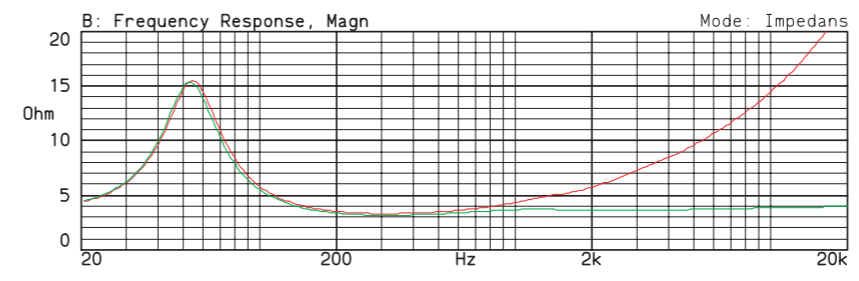

Impedance
(with and without impedance correction circuit)
Red line: impedance, free air
Green line: impedance, free air with compensation.
Measurement conditions:
Level: 2 V, 10 ohm
Driver in free air

Rigid die-cast chassis with aerodynamically shaped ribs
Materials and parameters are optimized for the harsh environmental conditions in a car
Smooth high-frequency roll-off
Natural midrange reproduction