

The new Esotec MW 172 is a 20 cm (8 inch) diameter mid/woofer designed for high performance two-and three way systems.

The MW 172 will perform extremely well in a wide range of enclosures, either sealed, vented, or free-air. The MW 172 exhibits a unique combination of smooth frequency response, low distortion, and extremely powerful bass to deliver an outstanding sonic performance in any high performance two- or three-way system.

The MW 172 utilizes an oversized 75 mm (3 inch) diameter voice coil to drive the MSP one-piece cone diaphragm. The new 15, 17 and 20 cm Esotec car series woofers all utilize new ultra compressed dual ferrite magnets positioned inside the coil to produce maximum utilization of the magnetic energy. The powerful double magnet system utilizes a vented pole piece for additional cooling. Positioning the magnet structure inside the voice coil enables the use of a very large voice coil, which in turn produces increased power and efficiency and yields a linear movement of the cone without cone breakup. Phase response is smooth and uniform. The large diameter of the voice coils provides optimum drive of the diaphragm and guarantees enough headroom with regard to power rating, while assuring perfect control of even the most minute membrane displacement. The use of a large diameter voice coil also allows for the flat Dynaudio MSP cone membrane geometry, which results in minimal phase lag at crossover to midrange driver.

The MW 172 is a perfectly balanced driver with excellent dispersion, a linear frequency response and an extraordinary absence of resonance, rendering it ideal for anchoring even a high quality two-way system even with its relatively large cone diameter.

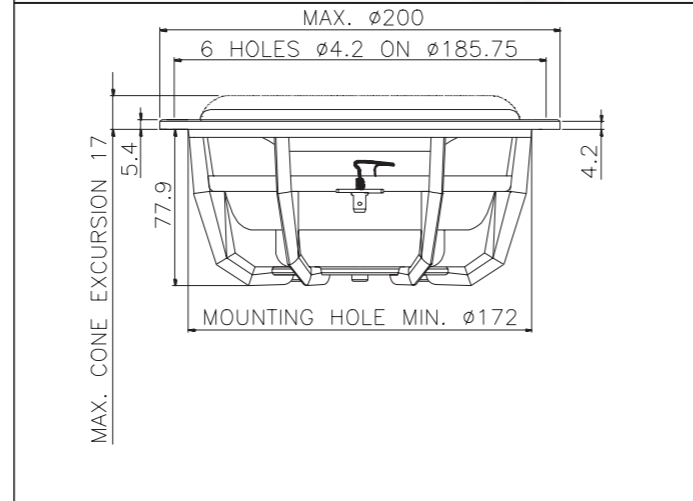

Thiele Small Parameters		
Nominal impedance	Znom	4 Ω
DC resistance	Re	3.2 Ω
Voice coil inductance	Le	0.27 mH
Resonance frequency	fs	45 Hz
Mechanical Q factor	Qms	2.3
Electrical Q factor	Qes	0.65
Total Q factor	Qts	0.51
Mechanical resistance	Rms	2.6 kg/s
Moving mass (incl. air load)	Mms	21.4 g
Suspension compliance	Cms	0.58 mm/N
Effective dome diameter	d	151 mm
Effective piston area	Sd	180 cm²
Equivalent volume	Vas	27 l
Force factor	BL	5.4 Tm
Recommended frequency range		35–3500 Hz

Magnet and Voice Coil Properties		
Voice coil diameter	dc	75 mm
Voice coil height	hc	14 mm
Linear excursion, peak to peak		9 mm
Max. excursion, peak to peak		15 mm

Power Handling		
Nominal long term IEC		150 W
Transient (10 ms)		1000 W

Mechanical Properties		
Net weight		1.6 kg
Overall dimension		ø 200 x 88 mm

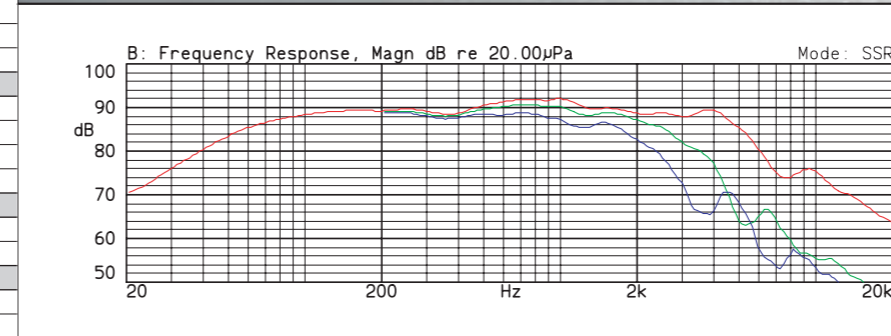
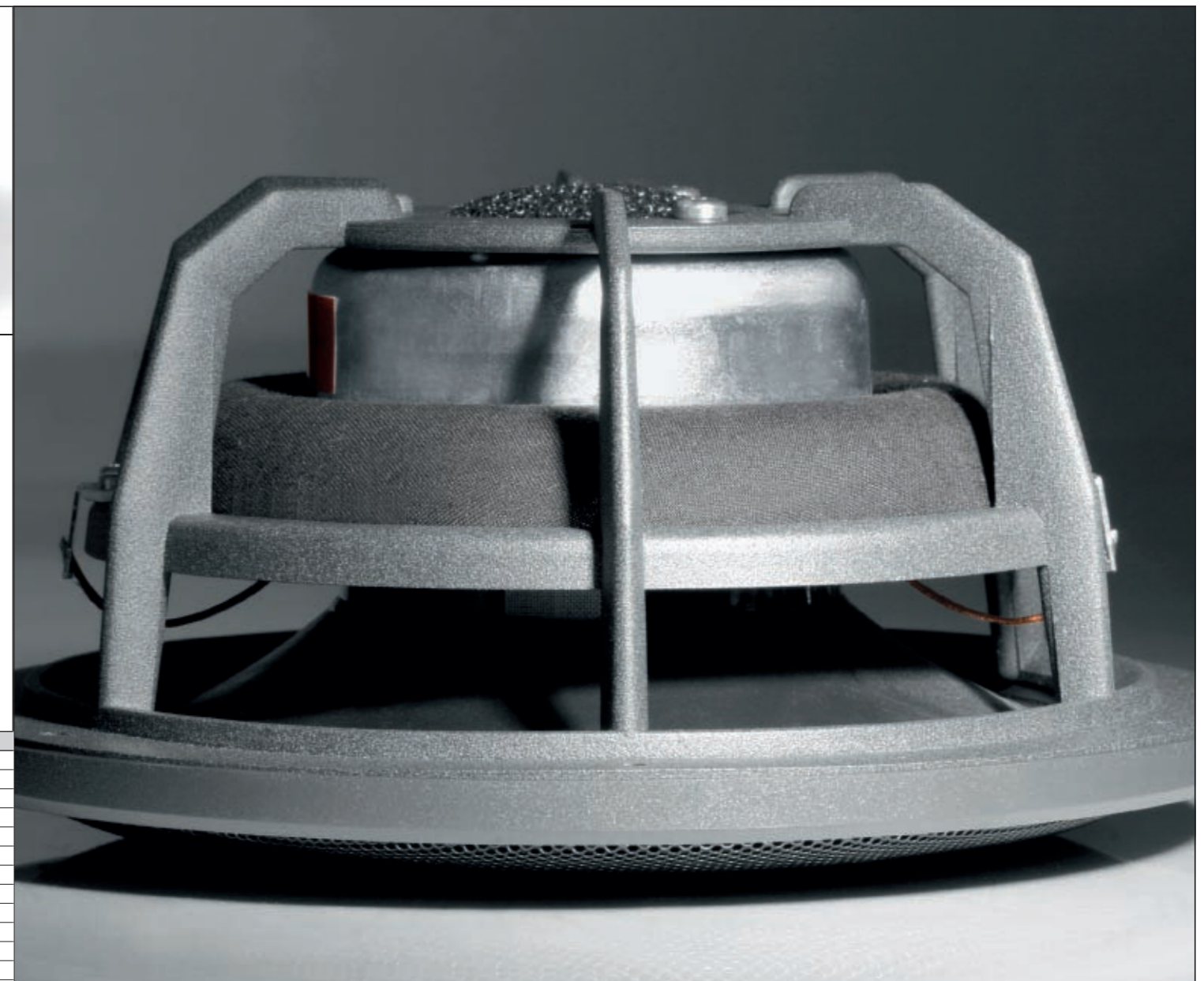
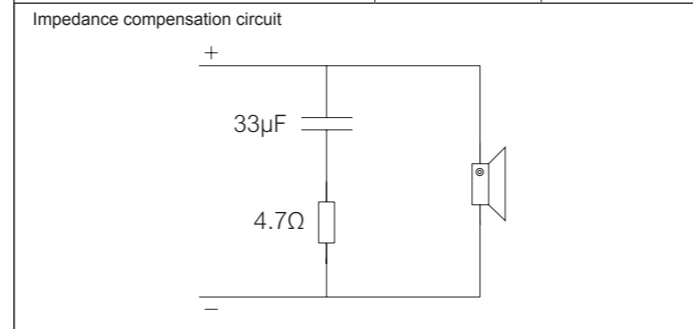

SPL

Red line: on-axis response
Green line: 30° horizontal
Blue line: 60° horizontal

Measurement conditions:
Level: 2.83 V
Distance: 1 m
Box volume: 18 l

Facts

- Diaphragm and dust cap moulded as one piece
- Very large 75 mm voice coil ensures high power handling
- Internal double magnet system with vented pole piece
- Aluminium voice coil wire provides for a low moving mass

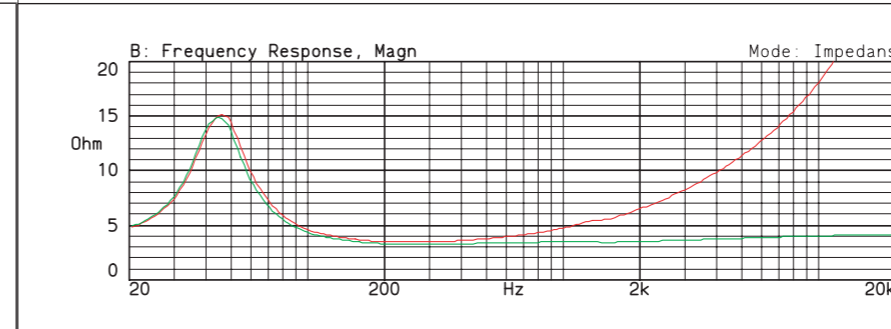

Impedance
(with and without impedance correction circuit)

Red line: impedance, free air
Green line: impedance, free air with compensation.

Measurement conditions:
Level: 2 V, 10 ohm
Driver in free air

- Rigid die-cast chassis with aerodynamically shaped ribs
- Materials and parameters are optimized for the harsh environmental conditions in a car
- Natural midrange reproduction
- Smooth high-frequency roll-off